

6.641, Electromagnetic Fields, Forces, and Motion
 Prof. Markus Zahn
Lecture 8: Magnetization

I. Magnetic Dipoles

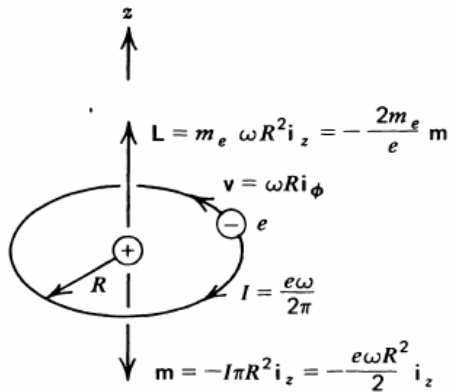

Figure 5-16 The orbiting electron has its magnetic moment \mathbf{m} in the direction opposite to its angular momentum \mathbf{L} because the current is opposite to the electron's velocity.

Courtesy of Krieger Publishing. Used with permission.

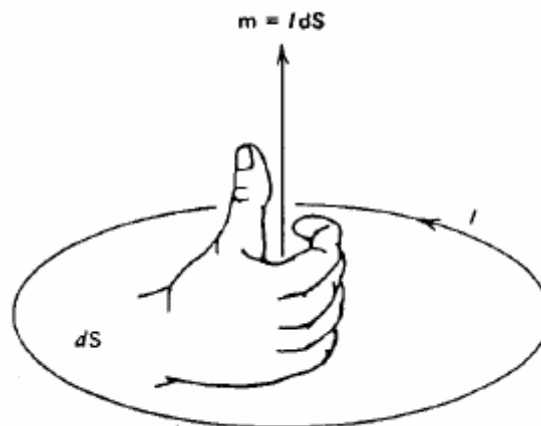

Figure 5-14 A magnetic dipole consists of a small circulating current loop. The magnetic moment is in the direction normal to the loop by the right-hand rule.

Courtesy of Krieger Publishing. Used with permission.

Diamagnetism

$$I = \frac{e}{2\pi/\omega} = \frac{e\omega}{2\pi}, \quad \bar{m} = -I\pi R^2 \bar{i}_z = \frac{-e\omega}{2\pi} \pi R^2 \bar{i}_z = \frac{-e\omega R^2}{2} \bar{i}_z$$

$$\text{Angular Momentum } \bar{L} = m_e R \bar{i}_r \times \bar{v} = m_e R (\omega R) (\bar{i}_r \times \bar{i}_\phi) = m_e \omega R^2 \bar{i}_z$$

$$\frac{(\bar{r} \times \bar{p})}{\text{linear momentum}} = -\frac{2m_e}{e} \bar{m}$$

L is quantized in units of $\frac{h}{2\pi}$, $h = 6.62 \times 10^{-34}$ joule – sec
(Planck's constant)

$$|\bar{m}| = \frac{e |\bar{L}|}{2m_e} = \frac{e h}{2\pi(2)m_e} = \frac{eh}{4\pi m_e} \approx 9.3 \times 10^{-24} \text{ amp} - \text{m}^2$$

Bohr magneton m_B
(smallest unit of magnetic moment)

Imagine all Bohr magnetons in sphere of radius R aligned. Net magnetic moment is

$$m = m_B \left(\frac{4}{3} \pi R^3 \rho \right) \frac{A_0}{M_0}$$

Total mass of sphere Avogadro's number = 6.023×10^{26} molecules per kilogram-mole
molecular weight

For iron: $\rho = 7.86 \times 10^3 \text{ kg/m}^3$, $M_0 = 56$

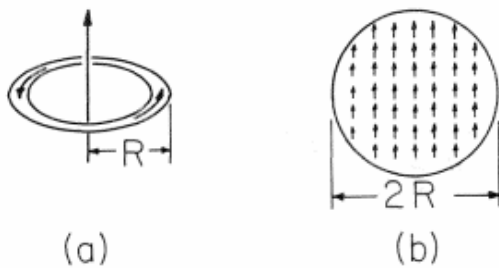

Figure 9.01 (a) Current i in loop of radius R gives dipole moment \mathbf{m} . (b) Spherical material of radius R has dipole moment approximated as the sum of atomic dipole moments.

Courtesy of Hermann A. Haus and James R. Melcher. Used with permission.

For a current loop

$$m = i \pi R^2 = m_B \frac{4}{3} \pi R^3 \rho \frac{A_0}{M_0} \Rightarrow i = m_B \frac{4}{3} R \rho \frac{A_0}{M_0}$$

$$\begin{aligned} \text{For } R = 10 \text{ cm} \Rightarrow i &= 9.3 \times 10^{-24} \left(\frac{4}{3}\right) (.1) 7.86 \times 10^3 \frac{(6.023 \times 10^{26})}{56} \\ &= 1.05 \times 10^5 \text{ Amperes} \end{aligned}$$

Thus, an ordinary piece of iron can have the same magnetic moment as a current loop of radius 10 cm of 10^5 Amperes current.

B. Magnetic Dipole Field

$$\vec{H} = \frac{\mu_0 m}{4 \pi r^3 \mu_0} \left[2 \cos \theta \vec{i}_r + \sin \theta \vec{i}_\theta \right] \quad (\text{multiply top \& bottom by } \mu_0)$$

Electric Dipole Field

$$\vec{E} = \frac{p}{4 \pi \epsilon_0 r^3} \left[2 \cos \theta \vec{i}_r + \sin \theta \vec{i}_\theta \right]$$

Analogy

$$p \rightarrow \mu_0 m$$

$$\vec{P} = N \vec{p} \Rightarrow \vec{M} = N \vec{m}, \quad N = \# \text{ of magnetic dipoles / volume}$$

$\begin{array}{l} | \quad \backslash \\ \text{Polarization} \quad \text{Magnetization} \end{array}$

II. Maxwell's Equations with Magnetization

EQS

$$\nabla \cdot (\epsilon_0 \vec{E}) = \rho_u - \nabla \cdot \vec{P}$$

$$\rho_p = -\nabla \cdot \vec{P} \quad (\text{Polarization or paired charge density})$$

$$\vec{n} \cdot [\epsilon_0 (\vec{E}^a - \vec{E}^b)] = -\vec{n} \cdot [\vec{P}^a - \vec{P}^b] + \sigma_{su}$$

MQS

$$\nabla \cdot (\mu_0 \vec{H}) = -\nabla \cdot (\mu_0 \vec{M})$$

$$\rho_m = -\nabla \cdot (\mu_0 \vec{M}) \quad (\text{magnetic charge density})$$

$$\vec{n} \cdot [\mu_0 (\vec{H}^a - \vec{H}^b)] = -\vec{n} \cdot [\mu_0 (\vec{M}^a - \vec{M}^b)]$$

$$\sigma_{sp} = -\bar{n} \cdot [\bar{P}^a - \bar{P}^b]$$

$$\sigma_{sm} = -\bar{n} \cdot [\mu_0 (\bar{M}^a - \bar{M}^b)]$$

$$\nabla \times \bar{H} = \bar{J}$$

$$\nabla \times \bar{E} = -\frac{\partial}{\partial t} \mu_0 (\bar{H} + \bar{M})$$

MQS Equations

$\bar{B} = \mu_0 (\bar{H} + \bar{M})$ Magnetic flux density \bar{B} has units of Teslas (1 Tesla = 10,000 Gauss)

$$\nabla \cdot \bar{B} = 0$$

$$\bar{n} \cdot [\bar{B}^a - \bar{B}^b] = 0$$

$$\nabla \times \bar{E} = -\frac{\partial \bar{B}}{\partial t}$$

$$\nabla \times \bar{H} = \bar{J}$$

$$v = \frac{d\lambda}{dt}, \quad \lambda = \int_S \bar{B} \cdot d\bar{a} \text{ (total flux)}$$

III. Magnetic Field Intensity along Axis of a Uniformly Magnetized Cylinder

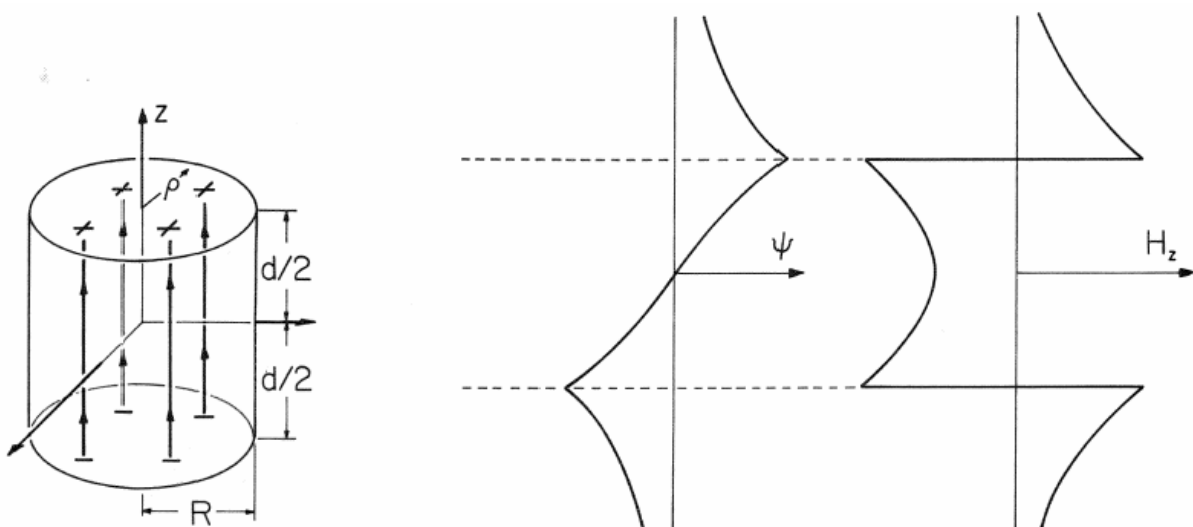

Figure 9.3.1 (a) Cylinder of circular cross-section uniformly magnetized in the direction of its axis. (b) Axial distribution of scalar magnetic potential and (c) axial magnetic field intensity. For these distributions, the cylinder length is assumed to be equal to its diameter.

$$\sigma_{sm} = -\vec{n} \cdot \mu_0 (\vec{M}^a - \vec{M}^b) \Rightarrow \sigma_{sm} (z = d/2) = \mu_0 M_0$$

$$\sigma_{sm} (z = -d/2) = -\mu_0 M_0$$

$$\nabla \times \vec{H} = \vec{J} = 0 \Rightarrow \vec{H} = -\nabla \Psi$$

$$\nabla (\mu_0 \vec{H}) = -\mu_0 \nabla^2 \Psi = \rho_m = -\nabla \cdot (\mu_0 \vec{M})$$

$$\nabla^2 \Psi = -\rho_m / \mu_0 \Rightarrow \Psi(\vec{r}) = \int_V \frac{\rho_m(\vec{r}') dV'}{4\pi\mu_0 |\vec{r} - \vec{r}'|}$$

$$\Psi(z) = \int_{r'=0}^R \frac{\sigma_{sm}(z = d/2) 2\pi r' dr'}{4\pi\mu_0 |\vec{r} - \vec{r}'|} + \int_{r'=0}^R \frac{\sigma_{sm}(z = -d/2) 2\pi r' dr'}{4\pi\mu_0 |\vec{r} - \vec{r}'|}$$

$$= \int_{r'=0}^R \frac{\mu_0 M_0 2\pi r' dr'}{4\pi\mu_0 \left[r'^2 + \left(z - \frac{d}{2} \right)^2 \right]^{1/2}} - \int_{r'=0}^R \frac{\mu_0 M_0 2\pi r' dr'}{4\pi\mu_0 \left[r'^2 + \left(z + \frac{d}{2} \right)^2 \right]^{1/2}}$$

$$\int \frac{r' dr'}{\left[r'^2 + (z+a)^2 \right]^{1/2}} = \left[r'^2 + (z+a)^2 \right]^{1/2}$$

$$\Psi(z) = \frac{M_0}{2} \left\{ \left[r'^2 + \left(z - \frac{d}{2} \right)^2 \right]^{1/2} \Big|_{r'=0}^R - \left[r'^2 + \left(z + \frac{d}{2} \right)^2 \right]^{1/2} \Big|_{r'=0}^R \right\}$$

$$= \frac{M_0}{2} \left\{ \left[R^2 + \left(z - \frac{d}{2} \right)^2 \right]^{1/2} - \left| z - \frac{d}{2} \right| - \left[R^2 + \left(z + \frac{d}{2} \right)^2 \right]^{1/2} + \left| z + \frac{d}{2} \right| \right\}$$

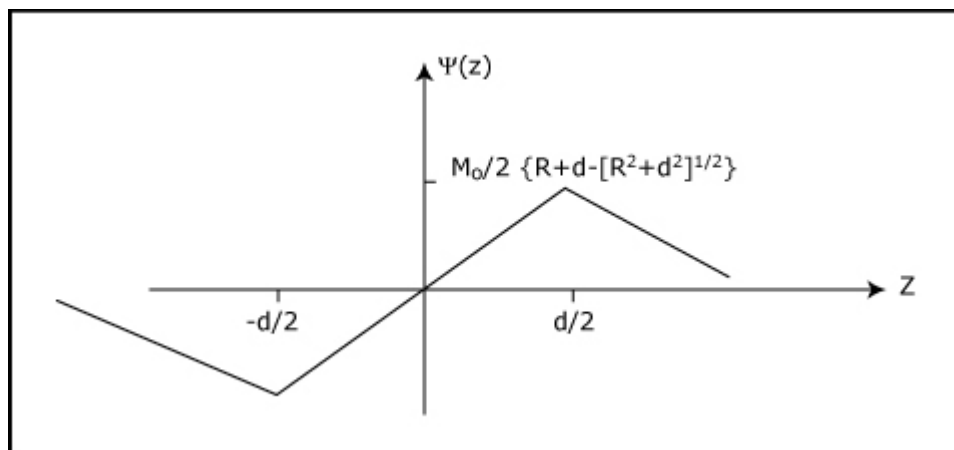

$$H_z = \frac{-\partial \Psi}{\partial z} = \begin{cases} \frac{-M_0}{2} \left\{ \frac{z - \frac{d}{2}}{\left[R^2 + \left(z - \frac{d}{2} \right)^2 \right]^{3/2}} - \frac{\left(z + \frac{d}{2} \right)}{\left[R^2 + \left(z + \frac{d}{2} \right)^2 \right]^{3/2}} \right\} & |z| > \frac{d}{2} \\ \frac{-M_0}{2} \left\{ \frac{z - \frac{d}{2}}{\left[R^2 + \left(z - \frac{d}{2} \right)^2 \right]^{3/2}} - \frac{\left(z + \frac{d}{2} \right)}{\left[R^2 + \left(z + \frac{d}{2} \right)^2 \right]^{3/2}} + 2 \right\} & -\frac{d}{2} < z < \frac{d}{2} \end{cases}$$

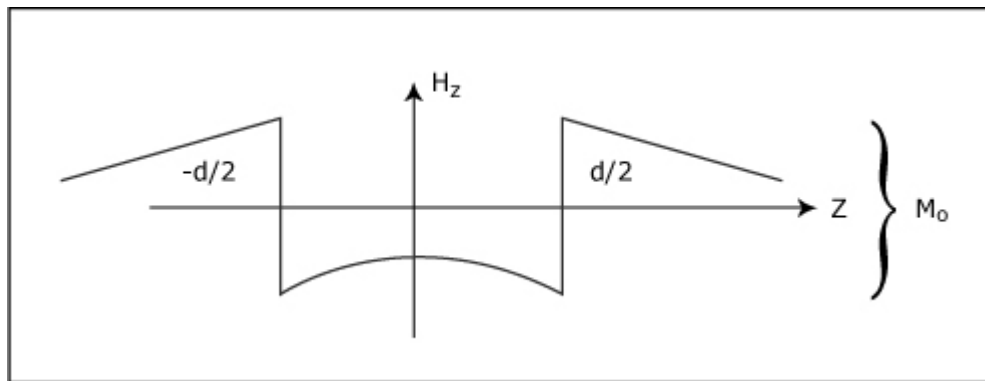

IV. Toroidal Coil

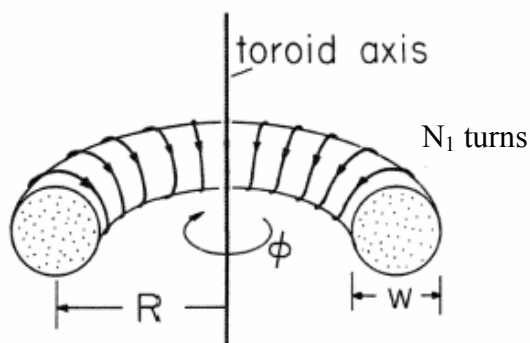

Figure 9.4.1 Toroidal coil with donut-shaped magnetizable core.

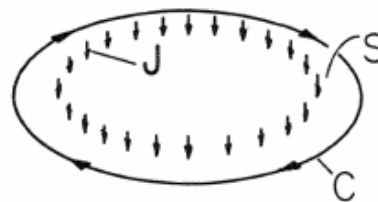

Figure 9.4.2 Surface S enclosed by contour C used with Ampère's integral law to determine \mathbf{H} in the coil shown in Figure 9.4.1.

Courtesy of Hermann A. Haus and James R. Melcher. Used with permission.

$$\oint_C \vec{H} \cdot d\vec{l} = H_\phi 2\pi r = N_1 i \Rightarrow H_\phi = \frac{N_1 i}{2\pi r} \approx \frac{N_1 i}{2\pi R}$$

$$\Phi \approx B \frac{\pi W^2}{4}$$

$$\lambda = N_2 \Phi = N_2 B \frac{\pi W^2}{4}$$

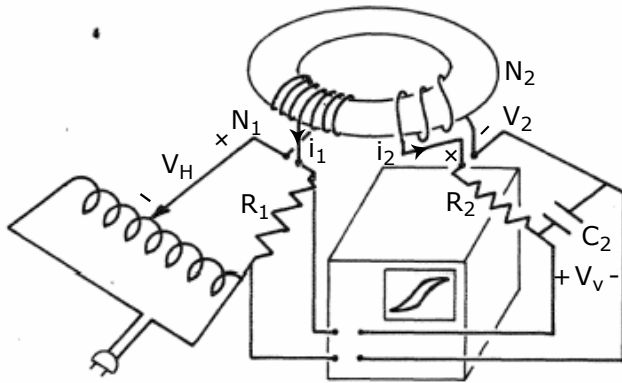

Figure 9.4.3 Demonstration in which the $B - H$ curve is traced out in the sinusoidal steady state.

Courtesy of Hermann A. Haus and James R. Melcher. Used with permission.

$$V_H = i_1 R_1 = R_1 \frac{H_\phi 2\pi R}{N_1} \quad (V_H = \text{Horizontal voltage to oscilloscope})$$

$$v_2 = \frac{d\lambda_2}{dt} = i_2 R_2 + V_v = V_v + R_2 C_2 \frac{dV_v}{dt}$$

$$\text{If } R_2 \gg \frac{1}{C_2 \omega} \Rightarrow \frac{d\lambda_2}{dt} \approx R_2 C_2 \frac{dV_v}{dt} \Rightarrow \lambda_2 = R_2 C_2 V_v \quad (V_v = \text{Vertical voltage to oscilloscope})$$

$$= \frac{\pi W^2}{4} N_2 B$$

$$V_v = \frac{1}{R_2 C_2} \frac{\pi W^2}{4} N_2 B$$

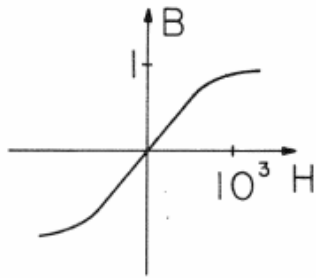

Figure 9.4.4 Typical magnetization curve without hysteresis. For typical ferromagnetic solids, the saturation flux density is in the range of 1–2 Tesla. For ferromagnetic domains suspended in a liquid, it is .02–.04 Tesla.

Courtesy of Hermann A. Haus and James R. Melcher. Used with permission.

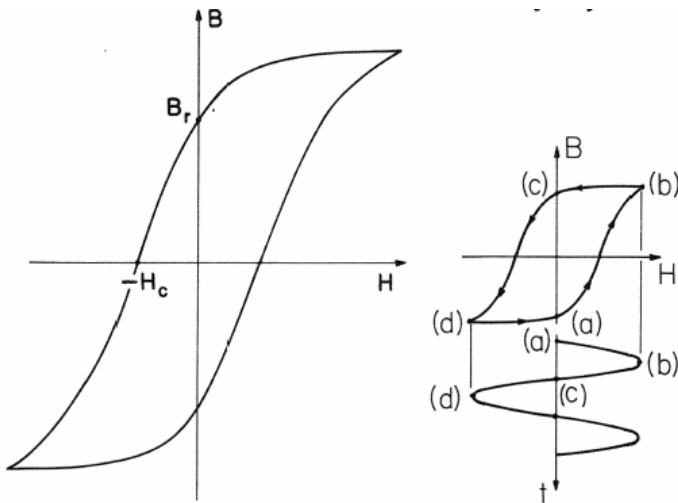

Figure 9.4.6 Magnetization characteristic for material showing hysteresis with typical values of B_r and H_c given in Table 9.4.2. The curve is obtained after many cycles of sinusoidal excitation in apparatus such as that of Figure 9.4.3. The trajectory is traced out in response to a sinusoidal current, as shown by the inset.

Courtesy of Hermann A. Haus and James R. Melcher. Used with permission.

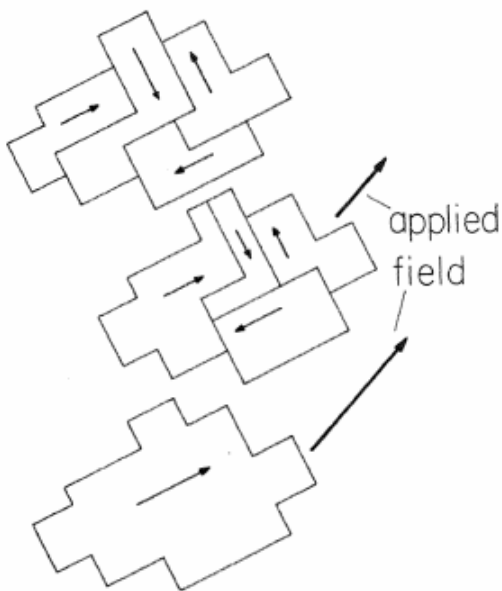

Figure 9.4.5 Polycrystalline ferromagnetic material viewed at the domain level. In the absence of an applied magnetic field, the domain moments tend to cancel. (This presumes that the material has not been left in a magnetized state by a previously applied field.) As a field is applied, the domain walls shift, giving rise to a net magnetization. In ideal materials, saturation results as all of the domains combine into one. In materials used for bulk fabrication of transformers, imperfections prevent the realization of this state.

Courtesy of Hermann A. Haus and James R. Melcher. Used with permission.

V. Magnetic Circuits

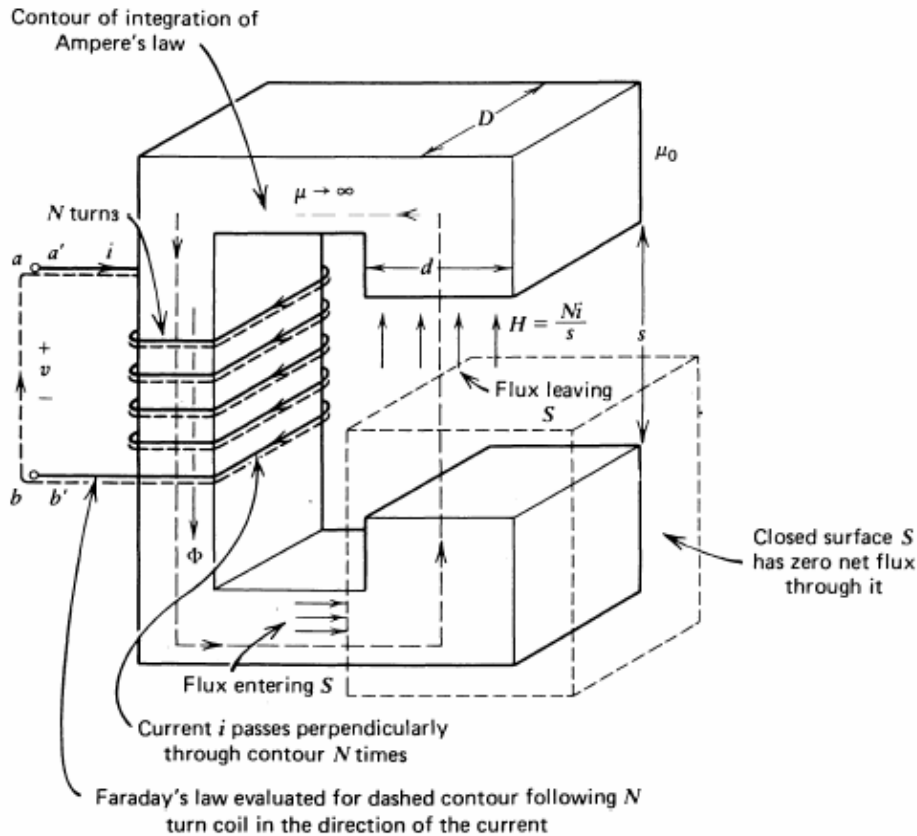

Figure 6-8 The magnetic field is zero within an infinitely permeable magnetic core and is constant in the air gap if we neglect fringing. The flux through the air gap is constant at every cross section of the magnetic circuit and links the N turn coil N times.

In iron core:

$$\lim_{\mu \rightarrow \infty} \bar{B} = \mu \bar{H} \Rightarrow \begin{cases} \bar{H} = 0 \\ \bar{B} \text{ finite} \end{cases}$$

$$\oint \bar{H} \cdot d\bar{l} = Hs = Ni \Rightarrow H = \frac{Ni}{s}$$

$$\Phi = \mu_0 H Dd = \frac{\mu_0 Dd N}{s} i$$

$$\oint_S \bar{B} \cdot d\bar{a} = 0$$

$$\lambda = N\Phi = \frac{\mu_0 Dd}{s} N^2 i \Rightarrow L = \frac{\lambda}{i} = \frac{\mu_0 Dd}{s} N^2$$

VI. Reluctance

$$\mathcal{R} = \frac{Ni}{\Phi} = \frac{s}{\mu_0 Dd} = \frac{(\text{length})}{(\text{permeability})(\text{cross-sectional area})}$$

[Reluctance, analogous to resistance]

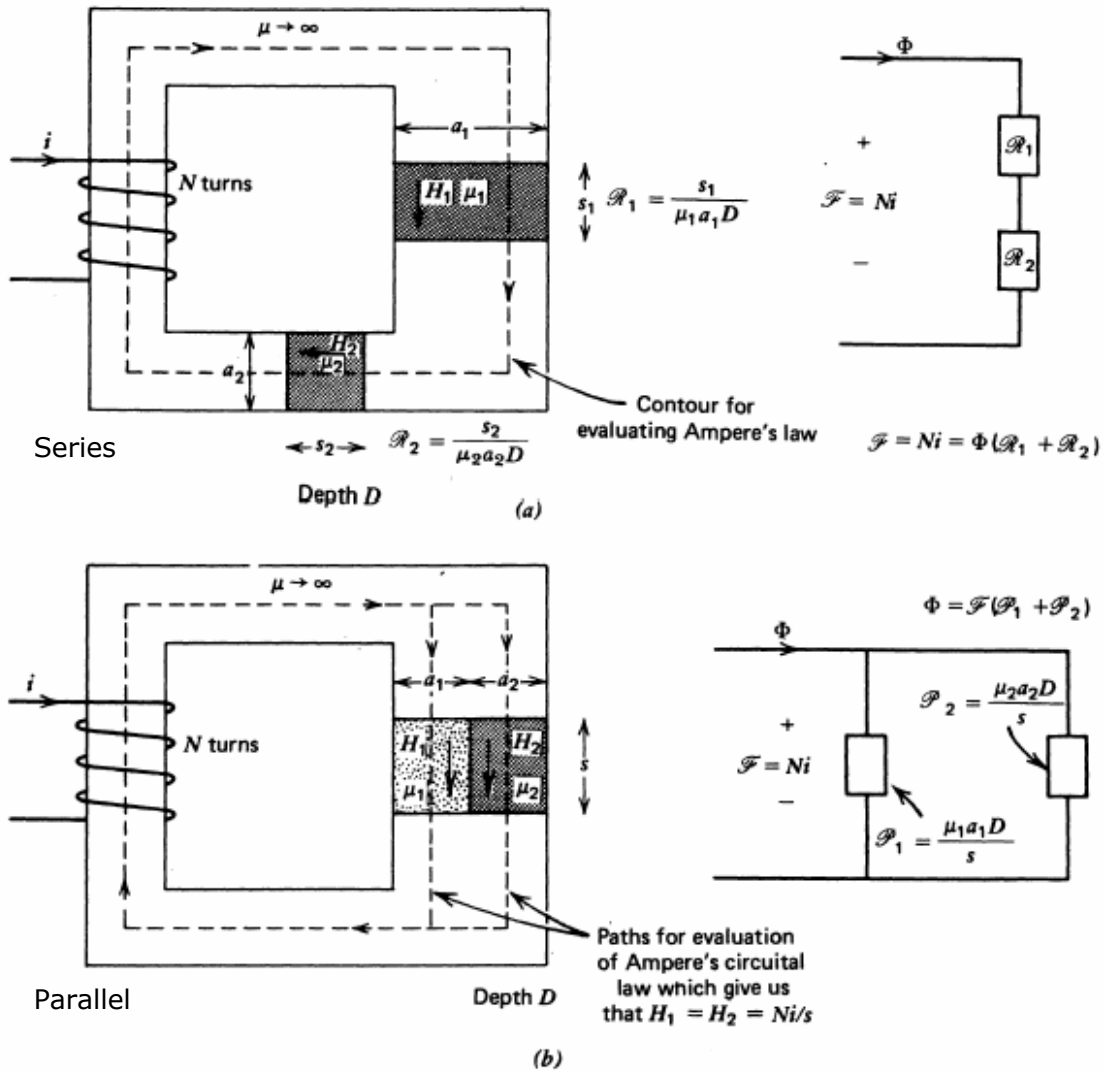

Figure 6-11 Magnetic circuits are most easily analyzed from a circuit approach where (a) reluctances in series add and (b) permeances in parallel add.

A. Reluctances In Series

$$\mathcal{R}_1 = \frac{s_1}{\mu_1 a_1 D}, \quad \mathcal{R}_2 = \frac{s_2}{\mu_2 a_2 D}$$

$$\Phi = \frac{Ni}{\mathcal{R}_1 + \mathcal{R}_2}$$

$$\oint_C \vec{H} \cdot d\vec{l} = H_1 s_1 + H_2 s_2 = Ni$$

$$\Phi = \mu_1 H_1 a_1 D = \mu_2 H_2 a_2 D$$

$$H_1 = \frac{\mu_2 a_2 Ni}{\mu_1 a_1 s_2 + \mu_2 a_2 s_1} ; \quad H_2 = \frac{\mu_1 a_1 Ni}{\mu_1 a_1 s_2 + \mu_2 a_2 s_1}$$

B. Reluctance In Parallel

$$\oint_C \vec{H} \cdot d\vec{l} = H_1 s = H_2 s = Ni \Rightarrow H_1 = H_2 = \frac{Ni}{s}$$

$$\Phi = (\mu_1 H_1 a_1 + \mu_2 H_2 a_2) D = \frac{Ni(\mathcal{R}_1 + \mathcal{R}_2)}{\mathcal{R}_1 \mathcal{R}_2} = Ni(\mathcal{P}_1 + \mathcal{P}_2)$$

$$\mathcal{P}_1 = \frac{1}{\mathcal{R}_1} ; \quad \mathcal{P}_2 = \frac{1}{\mathcal{R}_2}$$

$$\mathcal{P} = \frac{1}{\mathcal{R}} \text{ [Permeances, analogous to Conductance]}$$

VII. Transformers (Ideal)

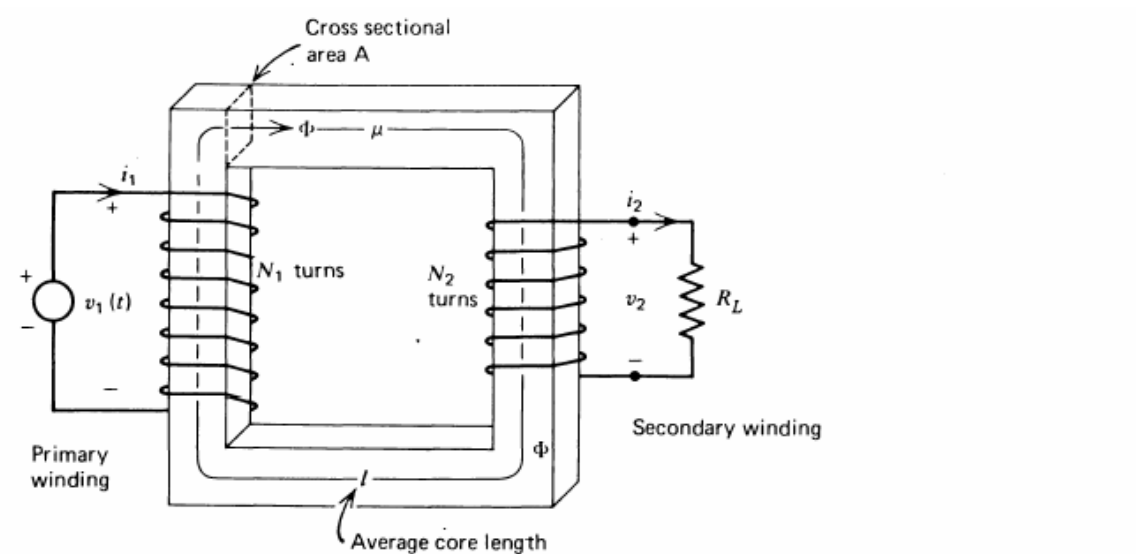

$$\left. \begin{aligned} \frac{v_1}{v_2} &= \frac{N_1}{N_2} \\ \frac{i_1}{i_2} &= \frac{N_2}{N_1} \end{aligned} \right\} \Rightarrow v_1 i_1 = v_2 i_2$$

(a)

Figure 6-13 (a) An ideal transformer relates primary and secondary voltages by the ratio of turns while the currents are in the inverse ratio so that the input power equals the output power. The \mathbf{H} field is zero within the infinitely permeable core. (b) In a real transformer the nonlinear \mathbf{B} - \mathbf{H} hysteresis loop causes a nonlinear primary current i_1 with an open circuited secondary ($i_2 = 0$) even though the imposed sinusoidal voltage $v_1 = V_0 \cos \omega t$ fixes the flux to be sinusoidal. (c) A more complete transformer equivalent circuit.

Courtesy of Krieger Publishing. Used with permission.

A. Voltage/Current Relationships

$$\Phi = \frac{N_1 i_1 - N_2 i_2}{\mathcal{R}}; \quad \mathcal{R} = \frac{l}{\mu A}$$

Another way: $\oint_C \mathbf{H} \cdot d\mathbf{l} = Hl = N_1 i_1 - N_2 i_2$

$$H = \frac{N_1 i_1 - N_2 i_2}{l}$$

$$\Phi = \mu H A = \frac{\mu A}{l} (N_1 i_1 - N_2 i_2) = \frac{N_1 i_1 - N_2 i_2}{\mathcal{R}}$$

$$\lambda_1 = N_1 \Phi = \frac{\mu A}{l} (N_1^2 i_1 - N_1 N_2 i_2) = L_1 i_1 - M i_2$$

$$\lambda_2 = N_2 \Phi = \frac{\mu A}{l} (N_1 N_2 i_1 - N_2^2 i_2) = -M i_1 + L_2 i_2$$

$$L_1 = N_1^2 L_0, \quad L_2 = N_2^2 L_0, \quad M = N_1 N_2 L_0, \quad L_0 = \frac{\mu A}{l} = \frac{1}{\mathcal{R}}$$

$$M = [L_1 L_2]^{1/2}$$

$$v_1 = \frac{d\lambda_1}{dt} = L_1 \frac{di_1}{dt} - M \frac{di_2}{dt} = N_1 L_0 \left[N_1 \frac{di_1}{dt} - N_2 \frac{di_2}{dt} \right]$$

$$v_2 = \frac{d\lambda_2}{dt} = +M \frac{di_1}{dt} - L_2 \frac{di_2}{dt} = N_2 L_0 \left[+N_1 \frac{di_1}{dt} - N_2 \frac{di_2}{dt} \right]$$

$$\frac{v_1}{v_2} = \frac{N_1}{N_2}$$

$$\lim_{\mu \rightarrow \infty} H \Rightarrow 0 \Rightarrow N_1 i_1 = N_2 i_2 \Rightarrow \frac{i_1}{i_2} = \frac{N_2}{N_1}$$

$$\frac{v_1 i_1}{v_2 i_2} = 1$$

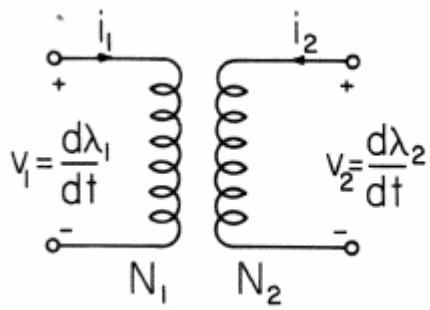

Figure 9.7.6 Circuit representation of a transformer as defined by the terminal relations of (12) or of an ideal transformer as defined by (13).

Courtesy of Hermann A. Haus and James R. Melcher. Used with permission.