



# 量子信息导论

## PHYS5251P

中国科学技术大学  
物理学院/合肥微尺度物质科学国家研究中心

陈凯

2024.3

# 第一章 量子体系

1. 量子态表示
2. 密度矩阵（纯态、混合态）
3. 量子不可克隆定理
- 4. Schmidt分解**
5. 密度矩阵（表示、操作）
6. 量子测量

# Schmidt decomposition

任意两体纯态

$$|\Phi\rangle = \sum_{i=1}^n \sum_{j=1}^m a_{ij} |i\rangle \otimes |j\rangle$$

假设  $n \leq m$

存在一组正交态  $|\mu_1\rangle, |\mu_2\rangle, \dots, |\mu_n\rangle$  以及  $|\varphi_1\rangle, |\varphi_2\rangle, \dots, |\varphi_n\rangle$  使得

$$|\Phi\rangle = \sum_{c=1}^n \sqrt{p_c} |m_c\rangle \otimes |j_c\rangle$$

$|\varphi_1\rangle, |\varphi_2\rangle, \dots, |\varphi_n\rangle$  为  $\text{Tr}_1 |\Phi\rangle\langle\Phi|$  的本征态

参考 QCQI § 2.5, M.A. Nielsen and I.L. Chuang

# 第一章 量子体系

1. 量子态表示
2. 密度矩阵（纯态、混合态）
3. 量子不可克隆定理
4. Schmidt分解
- 5. 密度矩阵（表示、操作）**
6. 量子测量

# 密度矩阵矩阵元的表示

$$I = \mathbf{S}_0 = \begin{pmatrix} 1 & 0 \\ 0 & 1 \end{pmatrix}, \mathbf{S}_1 = \begin{pmatrix} 0 & 1 \\ 1 & 0 \end{pmatrix}, \mathbf{S}_2 = \begin{pmatrix} 0 & -i \\ i & 0 \end{pmatrix}, \mathbf{S}_3 = \begin{pmatrix} 1 & 0 \\ 0 & -1 \end{pmatrix}$$

也即

$$I = |0\rangle\langle 0| + |1\rangle\langle 1|$$

$$\mathbf{S}_3 = |0\rangle\langle 0| - |1\rangle\langle 1|$$

$$\mathbf{S}_1 = |0\rangle\langle 1| + |1\rangle\langle 0|$$

$$\mathbf{S}_2 = -i|0\rangle\langle 1| + i|1\rangle\langle 0|$$

$$|0\rangle\langle 0| = \begin{pmatrix} 1 & 0 \\ 0 & 0 \end{pmatrix} = \frac{1}{2}(I + \mathbf{S}_3)$$

$$|0\rangle\langle 1| = \begin{pmatrix} 0 & 1 \\ 0 & 0 \end{pmatrix} = \frac{1}{2}(\mathbf{S}_1 + i\mathbf{S}_2)$$

$$|1\rangle\langle 1| = \begin{pmatrix} 0 & 0 \\ 0 & 1 \end{pmatrix} = \frac{1}{2}(I - \mathbf{S}_3)$$

$$|1\rangle\langle 0| = \begin{pmatrix} 0 & 0 \\ 1 & 0 \end{pmatrix} = \frac{1}{2}(\mathbf{S}_1 - i\mathbf{S}_2)$$

# 密度矩阵性质

$$\begin{aligned}\rho^2 &= \rho * \rho \\ &= \sum_i p_i |\psi_i\rangle \langle \psi_i| \sum_j p_j |\psi_j\rangle \langle \psi_j| \\ &= \sum_i p_i p_j |\psi_i\rangle \langle \psi_i | \psi_j\rangle \langle \psi_j| \\ &= \sum_i p_i^2 |\psi_i\rangle \langle \psi_i|.\end{aligned}$$

因此

$$\text{Tr} \rho^2 = \sum_i p_i^2 \quad \text{混合程度, 最小值?}$$

纯态

$$\sum_i p_i^2 = 1$$

$$\rho = \frac{1}{d} \mathbb{1}$$

混合态

$$\text{tr}(\rho^2) < 1$$

# 密度矩阵性质

所有N维Hilbert空间H中的密度矩阵构成一个凸集

$$r(l) = l r_1 + (1-l) r_2$$

(i)  $\rho$  is positive:  $\langle \varphi | \rho | \varphi \rangle \geq 0, \forall |\varphi\rangle \in \mathcal{H}_d$  (and thus Hermitian,  $\rho^\dagger = \rho$ )

(ii)  $tr[\rho] = 1$

一般地

$$\rho = \sum_{l=1}^k r_l \rho_l$$

仍然为一个密度矩阵



# 密度矩阵演化

作用一个么正变换 $U$ 在初态  $|\mathbf{y}\rangle$  ， 我们有

$$U|\mathbf{y}\rangle$$

密度矩阵变为

$$U|\mathbf{y}\rangle\langle\mathbf{y}|U^\dagger$$



# 密度矩阵演化

作用一个么正变换 $U$ 在一个系统上  $\{q_k, |\mathbf{y}_k\rangle\}$ ，我们  
有  $\{q_k, U|\mathbf{y}_k\rangle\}$

密度矩阵变为

$$\begin{aligned} & \sum_k q_k U|\mathbf{y}_k\rangle\langle\mathbf{y}_k|U^\dagger \\ &= U\left(\sum_k q_k |\mathbf{y}_k\rangle\langle\mathbf{y}_k|\right)U^\dagger \\ &= URU^\dagger \end{aligned}$$

# 系综分解

## 任意系综生成和表示

$$\rho = \sum_a p_a |\psi_a\rangle\langle\psi_a| = \sum_a |\tilde{\psi}_a\rangle\langle\tilde{\psi}_a|, \quad |\tilde{\psi}_a\rangle := \sqrt{p_a}|\psi_a\rangle,$$

## 正交归一基矢下的系综分解

$$\rho = \sum_{n=1}^d \lambda_n |n\rangle\langle n| = \sum_{n=1}^d |\tilde{n}\rangle\langle\tilde{n}|$$

可以证明，同一密度矩阵的两组系综之间存在一个幺正变换关系

$$|\tilde{\psi}_i\rangle = \sum_j u_{ij} |\tilde{\varphi}_j\rangle$$

# Trace操作

$$\text{tr}(\rho) = \sum_k \langle k | \rho | k \rangle$$

对于混合态

$$\rho = \sum_i p_i |\psi_i\rangle \langle \psi_i|$$

$$\begin{aligned} \text{tr}(\rho) &= \sum_k \langle k | \sum_i p_i |\psi_i\rangle \langle \psi_i| | k \rangle \\ &= \sum_i p_i \text{tr}(|\psi_i\rangle \langle \psi_i|) \\ &= \sum_i p_i \\ &= 1. \end{aligned}$$

意味着对于各种量子态的测量输出总的概率为1

# Trace操作性质

矩阵对角元求和

$$\text{Tr} \begin{bmatrix} a_{00} & a_{01} & a_{02} \\ a_{10} & a_{11} & a_{12} \\ a_{20} & a_{21} & a_{22} \end{bmatrix} = a_{00} + a_{11} + a_{22}$$

特性

$$\text{Tr}[xA + yB] = x\text{Tr}[A] + y\text{Tr}[B]$$

$$\text{Tr}[AB] = \text{Tr}[BA]$$

$$\text{Tr}[ABC] = \text{Tr}[CAB]$$

$$\text{Tr}[UAU^\dagger] = \text{Tr}[A]$$

$$\text{Tr}[A] = \sum_i \langle \varphi_i | A | \varphi_i \rangle$$

正交基展开  $|\varphi_i\rangle$

# Trace操作

$$\text{Tr}(|y\rangle\langle j|) = \langle j|y\rangle^*$$

可分离态情形

$$\rho_A \otimes \rho_B = \sum_{ij} (|p_i\rangle\langle i_A|) \otimes (|q_i\rangle\langle j_B|)$$

$$\text{Tr}_B(\rho_A \otimes \rho_B) = \rho_A \otimes \text{Tr}(\rho_B)$$



# Trace操作

纠缠态情形

$$\text{Tr}(|y\rangle\langle j|) = \langle j|y\rangle^*$$

$$|\psi_{AB}\rangle = \sum_i \alpha_i |i_A\rangle |i_B\rangle$$

$$\rho_{AB} = |\psi_{AB}\rangle\langle\psi_{AB}| = \sum_i \alpha_i |i_A\rangle |i_B\rangle \sum_j \alpha_j^* \langle j_A| \langle j_B|$$

我们得到

$$\begin{aligned} \text{tr}_B \rho_{AB} &= \sum_{i,j} \alpha_i \alpha_j^* |i_A\rangle \langle j_A| \langle j_B| |i_B\rangle \\ &= \sum_{i,j} \alpha_i \alpha_j^* |i_A\rangle \langle j_A| \delta_{ij} \\ &= \sum_i |\alpha_i|^2 |i_A\rangle \langle i_A|. \end{aligned}$$

# Trace操作

一个例子

$$|\Phi^+\rangle = \frac{1}{\sqrt{2}}(|0_A 0_B\rangle + |1_A 1_B\rangle)$$

我们得到

$$\begin{aligned} \text{Tr}_B(|\Phi^+\rangle\langle\Phi^+|) &= \text{Tr}_B\left(\frac{1}{2}(|0_A 0_B\rangle + |1_A 1_B\rangle)(\langle 0_A 0_B| + \langle 1_A 1_B|)\right) \\ &= \frac{1}{2}(|0_A\rangle\langle 0_A| \otimes \text{Tr}(|0_B\rangle\langle 0_B|) + |1_A\rangle\langle 0_A| \otimes \text{Tr}(|1_B\rangle\langle 0_B|) + |0_A\rangle\langle 1_A| \otimes \text{Tr}(|0_B\rangle\langle 1_B|) + |1_A\rangle\langle 1_A| \otimes \text{Tr}(|1_B\rangle\langle 1_B|)) \\ &= \frac{1}{2}(|0_A\rangle\langle 0_A| + |1_A\rangle\langle 1_A|) \end{aligned}$$

量子态纯化Purification

$$\rho = \sum_i p_i |i\rangle\langle i|$$

$$|\psi\rangle = \sum_i \sqrt{p_i} |i_A\rangle \otimes |i_B\rangle$$

# Trace操作 作用在矩阵上

$$\begin{bmatrix} a_{00} & a_{01} & a_{02} & a_{03} \\ a_{10} & a_{11} & a_{12} & a_{13} \\ a_{20} & a_{21} & a_{22} & a_{23} \\ a_{30} & a_{31} & a_{32} & a_{33} \end{bmatrix} \xrightarrow{Tr_2} \begin{bmatrix} Tr \begin{bmatrix} a_{00} & a_{01} \\ a_{10} & a_{11} \end{bmatrix} & Tr \begin{bmatrix} a_{02} & a_{03} \\ a_{12} & a_{13} \end{bmatrix} \\ Tr \begin{bmatrix} a_{20} & a_{21} \\ a_{30} & a_{31} \end{bmatrix} & Tr \begin{bmatrix} a_{22} & a_{23} \\ a_{32} & a_{33} \end{bmatrix} \end{bmatrix}$$
$$= \begin{bmatrix} a_{00} + a_{11} & a_{02} + a_{13} \\ a_{20} + a_{31} & a_{22} + a_{33} \end{bmatrix}$$



# 约化密度矩阵 一练习

$$|\Phi\rangle_{AB} = \sum_{ij} a_{ij} |ij\rangle_{AB}$$

$$A_{ij} = a_{ij}$$

$$\mathbf{r}_A = ?$$

$$\mathbf{r}_B = ?$$

# 第一章 量子体系

1. 量子态表示
2. 密度矩阵（纯态、混合态）
3. 量子不可克隆定理
4. Schmidt分解
5. 密度矩阵（表示、操作）
- 6. 量子测量**

# 量子测量

$$|f\rangle = \sum_{i=1}^n a_i |b_i\rangle, \quad \sum_{i=1}^n |a_i|^2 = 1$$

沿基矢  $\{b_i\}_{i=1}^n$  进行测量

几率幅  $a_i = \langle b_i | f \rangle$

几率  $|a_i|^2$

量子测量 如对于任意叠加态

$$|\psi\rangle = \alpha|0\rangle + \beta|1\rangle, \quad |\alpha|^2 + |\beta|^2 = 1$$

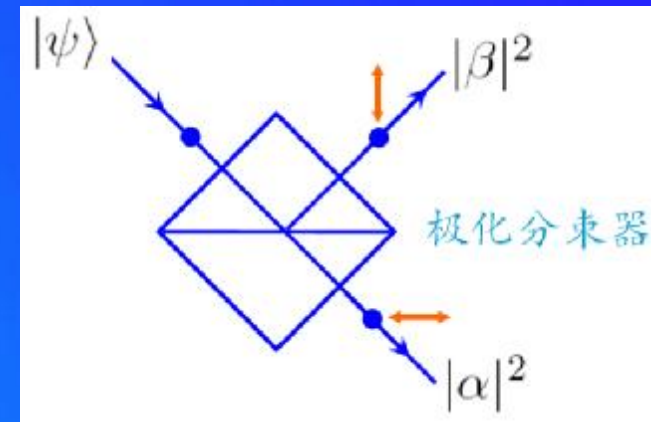

# Von Neumann测量

Von Neumann测量是投影测量的一种类型。给定一组正交基  $\{|y_k\rangle\}$ ，如果我们对于量子态  $|\Phi\rangle = \sum a_k |y_k\rangle$  实施沿基矢  $|y_k\rangle$  的 Von Neumann测量，则有

$$\begin{aligned} |a_k|^2 &= |\langle y_k | \Phi \rangle|^2 = \langle y_k | \Phi \rangle \langle \Phi | y_k \rangle \\ &= \text{Tr}(\langle y_k | \Phi \rangle \langle \Phi | y_k \rangle) = \text{Tr}(|y_k\rangle \langle y_k| \Phi \langle \Phi|) \end{aligned}$$

# Von Neumann测量

例如考虑对于量子态  $|\Phi\rangle = (a|0\rangle + b|1\rangle)$

实施相对于基矢  $\left\{ \frac{|0\rangle + |1\rangle}{\sqrt{2}}, \frac{|0\rangle - |1\rangle}{\sqrt{2}} \right\}$  的 Von Neumann 测量

注意到  $|\Phi\rangle = \frac{a+b}{\sqrt{2}} \left( \frac{|0\rangle + |1\rangle}{\sqrt{2}} \right) + \frac{a-b}{\sqrt{2}} \left( \frac{|0\rangle - |1\rangle}{\sqrt{2}} \right)$

因此我们有测得  $\left( \frac{|0\rangle + |1\rangle}{\sqrt{2}} \right)$  的几率为  $\frac{|a+b|^2}{2}$

# Von Neumann测量

实际上

$$\left( \frac{\langle 0| + \langle 1|}{\sqrt{2}} \right) \Phi \rangle = \frac{a + b}{\sqrt{2}}$$

$$\langle \Phi | \left( \frac{|0\rangle + |1\rangle}{\sqrt{2}} \right) = \frac{a^* + b^*}{\sqrt{2}}$$

$$\left( \frac{\langle 0| + \langle 1|}{\sqrt{2}} \right) \Phi \rangle \langle \Phi | \left( \frac{|0\rangle + |1\rangle}{\sqrt{2}} \right)$$

$$= \text{Tr} \left( \left( \frac{|0\rangle + |1\rangle}{\sqrt{2}} \right) \left( \frac{\langle 0| + \langle 1|}{\sqrt{2}} \right) \Phi \rangle \langle \Phi | \right) = \frac{|a + b|^2}{2}$$

# 投影测量(Projective measurements)

可观测量 $M$ 存在一个谱分解

$$M = \sum_m m P_m$$

满足

$$P_m P_n = P_m \delta_{m,n}$$

$$\sum_m P_m = I$$

获得结果 $m$ 的几率为

$$p(m) = \text{tr}(P_m \rho)$$

系统的量子态变为

$$\frac{P_m \rho P_m}{p(m)}$$

# 投影测量(Projective measurements)

可观测量 $M$ 存在一个谱分解

$$\mathbf{S}_1 = \begin{pmatrix} 0 & 1 \\ 1 & 0 \end{pmatrix}, \mathbf{S}_2 = \begin{pmatrix} 0 & -i \\ i & 0 \end{pmatrix}, \mathbf{S}_3 = \begin{pmatrix} 1 & 0 \\ 0 & -1 \end{pmatrix}$$

$$\mathbf{S}_1 = |0\rangle\langle 1| + |1\rangle\langle 0|$$

$$\mathbf{S}_2 = -i|0\rangle\langle 1| + i|1\rangle\langle 0|$$

$$\mathbf{S}_3 = |0\rangle\langle 0| - |1\rangle\langle 1|$$

更一般地定义可观测量

$$\vec{v} \cdot \vec{\sigma} \equiv v_1 \sigma_1 + v_2 \sigma_2 + v_3 \sigma_3$$

称为自旋沿着  $\vec{v}$  轴方向的测量





# 广义测量

*Quantum measurements are described by a collection  $\{M_m\}$  of measurement operators. These are operators acting on the state space of the system being measured. The index  $m$  refers to the measurement outcomes that may occur in the experiment.*

对于量子态，结果 $m$ 发生的几率为

$$p(m) = \langle \psi | M_m^\dagger M_m | \psi \rangle$$

测量后的系统处于

$$\frac{M_m |\psi\rangle}{\sqrt{\langle \psi | M_m^\dagger M_m | \psi \rangle}}$$



# 广义测量

其中测量算符满足完备性条件

$$\sum_m M_m^\dagger M_m = I$$

可见

$$1 = \sum_m p(m) = \sum_m \langle \psi | M_m^\dagger M_m | \psi \rangle$$

# 例子

我们有投影算子  $M_0 = |0\rangle\langle 0|$  和  $M_1 = |1\rangle\langle 1|$

满足

$$M_0^2 = M_0, M_1^2 = M_1$$

$$I = M_0^\dagger M_0 + M_1^\dagger M_1 = M_0 + M_1$$

从而

$$p(0) = \langle \psi | M_0^\dagger M_0 | \psi \rangle = \langle \psi | M_0 | \psi \rangle = |a|^2$$

同理

$$p(1) = |b|^2$$

测量之后量子态处于

$$\frac{M_0|\psi\rangle}{|a|} = \frac{a}{|a|}|0\rangle$$
$$\frac{M_1|\psi\rangle}{|b|} = \frac{b}{|b|}|1\rangle.$$



# 广义测量是可实现的

任意广义的量子测量均可以通过纠缠该系统与一个辅助系统，应用一个幺正变换并实施投影测量来实现

量子系统A，测量算符 $M_m$ ，辅助系统B

定义

$$U |\psi\rangle |0\rangle = \sum_m M_m |\psi\rangle |m\rangle$$

可见

$$\langle\varphi| \langle 0| U^\dagger U |\psi\rangle |0\rangle = \sum_m \langle\varphi| M_m^\dagger M_m |\psi\rangle = \langle\varphi|\psi\rangle$$

实施投影测量

$$P_m \equiv I \otimes |m\rangle \langle m|$$

从而有输出m的几率为

$$\begin{aligned} p(m) &= \langle\psi| \langle 0| U^\dagger P_m U |\psi\rangle |0\rangle \\ &= \sum_{m', m''} \langle\psi| M_{m'}^\dagger \langle m'| (I_Q \otimes |m\rangle \langle m|) M_{m''} |\psi\rangle |m''\rangle \\ &= \langle\psi| M_m^\dagger M_m |\psi\rangle, \end{aligned}$$

# 广义测量是可实现的

任意广义的量子测量均可以通过纠缠该系统与一个辅助系统，应用一个幺正变换并实施投影测量来实现

量子系统A，测量算符 $M_m$ ，辅助系统B

测量之后的联合量子态处于

$$\frac{P_m U |\psi\rangle |0\rangle}{\sqrt{\langle \psi | U^\dagger P_m U | \psi \rangle}} = \frac{M_m |\psi\rangle |m\rangle}{\sqrt{\langle \psi | M_m^\dagger M_m | \psi \rangle}}$$

要测量的系统处于

$$\frac{M_m |\psi\rangle}{\sqrt{\langle \psi | M_m^\dagger M_m | \psi \rangle}}$$



# POVM测量

— Positive Operator-Valued Measure

量子系统A，测量算符 $M_m$ ,

对于量子态，结果 $m$ 发生的几率为

$$p(m) = \langle \psi | M_m^\dagger M_m | \psi \rangle$$

定义

$$E_m \equiv M_m^\dagger M_m$$

我们有

$$\sum_m E_m = I \text{ and } p(m) = \langle \psi | E_m | \psi \rangle$$

可见集合 $E_m$ 本身就可以决定所有可能的不同测量输出的几率

# How to distinguish non-orthogonal states optimally

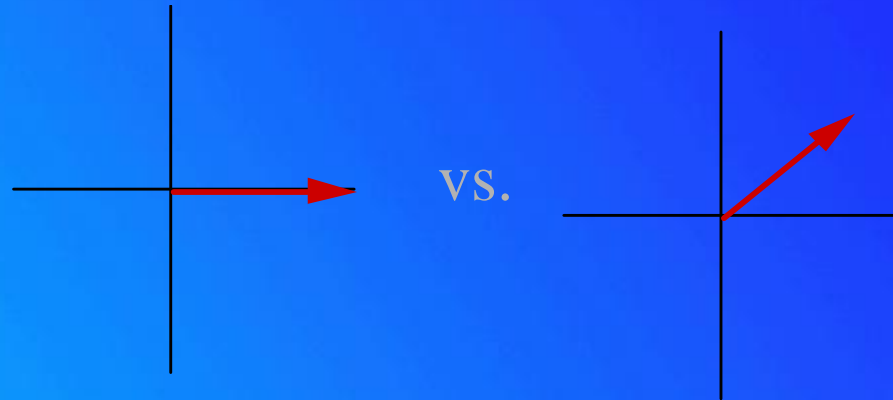

**H-polarized photon**

**45°-polarized photon**

From Steinberg

Use generalized (POVM) quantum measurements.

[see, e.g., Y. Sun, J. Bergou, and M. Hillery, Phys. Rev. A 66, 032315 (2002).]

The view from the laboratory:

A measurement of a two-state system can only yield two possible results.

If the measurement isn't guaranteed to succeed, there are three possible results: (1), (2), and ("I don't know").

Therefore, to discriminate between two non-orth. states, we need to use an expanded (3D or more) system. To distinguish 3 states, we need 4D or more.



# The geometric picture

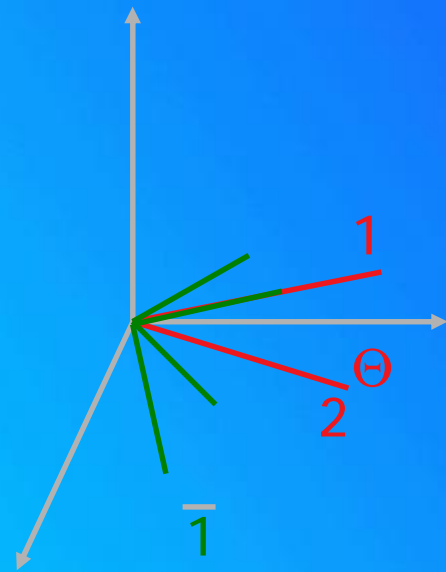

Two non-orthogonal vectors

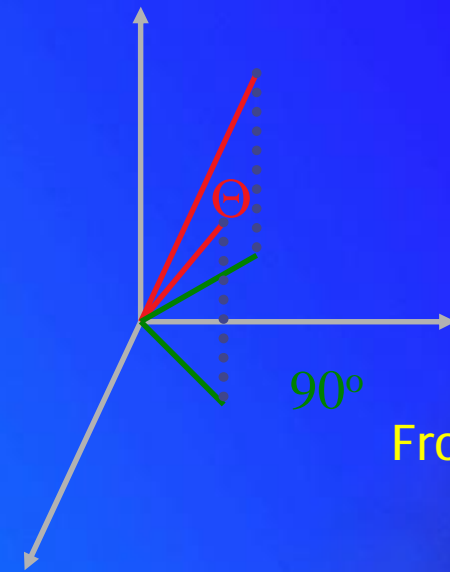

From Steinberg

The same vectors rotated so their *projections* onto x-y are orthogonal

(The z-axis is “inconclusive”)



# A test case

Consider these three non-orthogonal states:

$$|\psi_1\rangle_{in} = \begin{pmatrix} \sqrt{2/3} \\ 0 \\ 1/\sqrt{3} \end{pmatrix} ; |\psi_2\rangle_{in} = \begin{pmatrix} 0 \\ 1/\sqrt{3} \\ \sqrt{2/3} \end{pmatrix} ; |\psi_3\rangle_{in} = \begin{pmatrix} 0 \\ -1/\sqrt{3} \\ \sqrt{2/3} \end{pmatrix}$$

Projective measurements can distinguish these states with *certainty* no more than 1/3 of the time.

(No more than one member of an orthonormal basis is orthogonal to *two* of the above states, so only one pair may be ruled out.)

But a unitary transformation in a 4D space produces: From Steinberg

$$|\psi_1\rangle_{out} = \begin{pmatrix} 1/\sqrt{3} \\ 0 \\ 0 \\ \sqrt{2/3} \end{pmatrix} \quad |\psi_2\rangle_{out} = \begin{pmatrix} 0 \\ 1/\sqrt{3} \\ 1/\sqrt{3} \\ 1/\sqrt{3} \end{pmatrix} \quad |\psi_3\rangle_{out} = \begin{pmatrix} 0 \\ -1/\sqrt{3} \\ 1/\sqrt{3} \\ 1/\sqrt{3} \end{pmatrix}$$

...and these states can be distinguished with certainty up to 55% of the time

# Experimental schematic

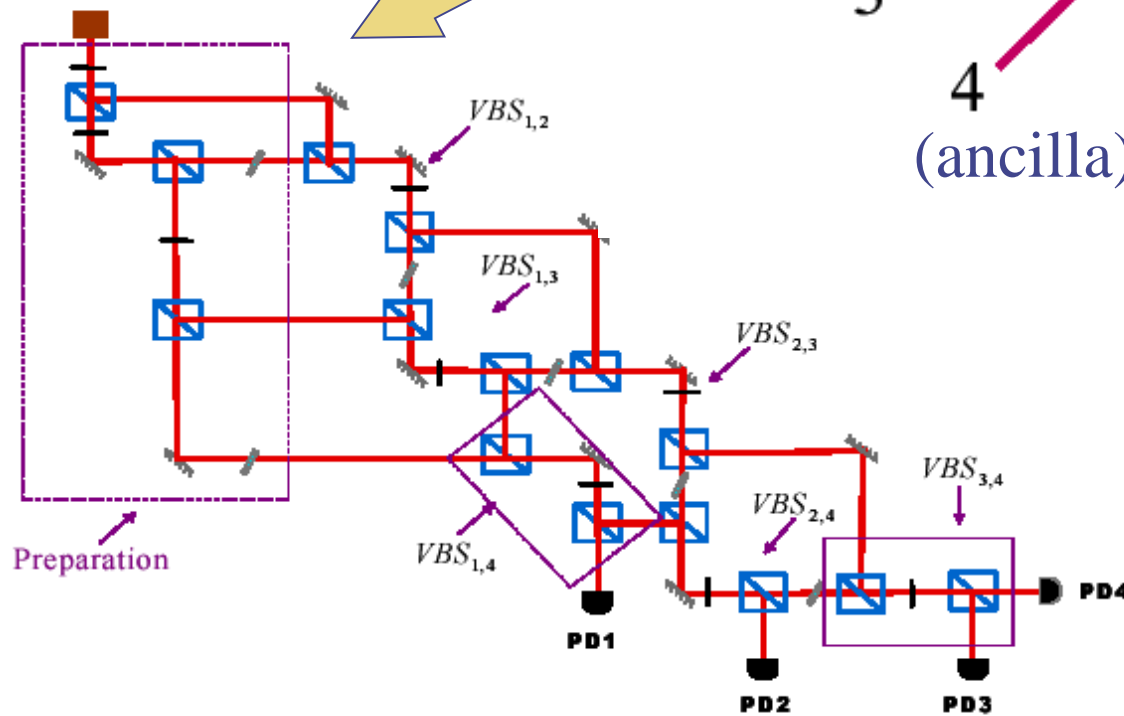
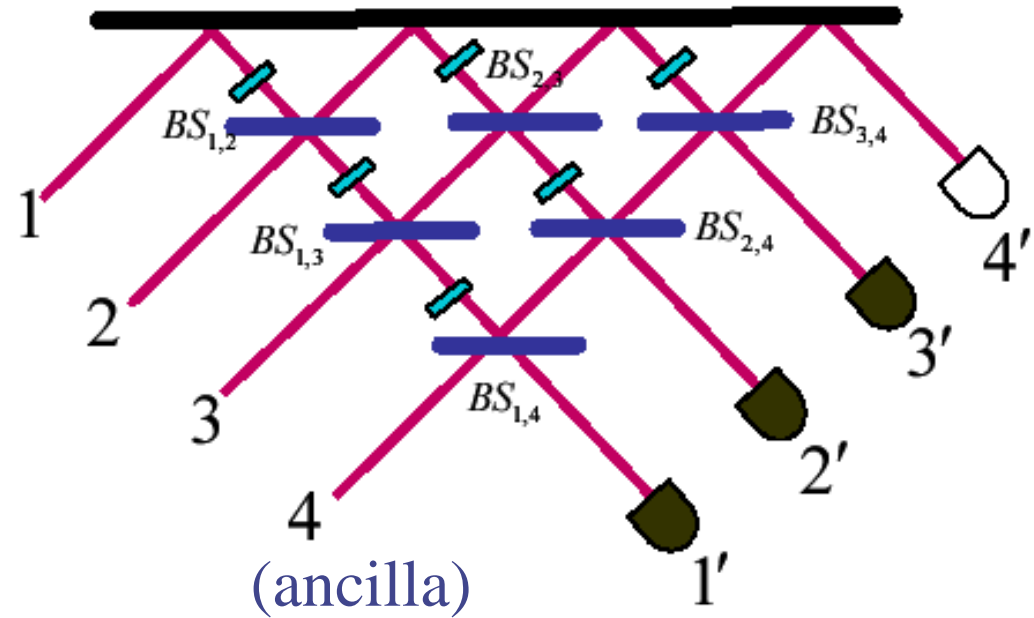

# A 14-path interferometer for arbitrary 2-qubit unitaries...

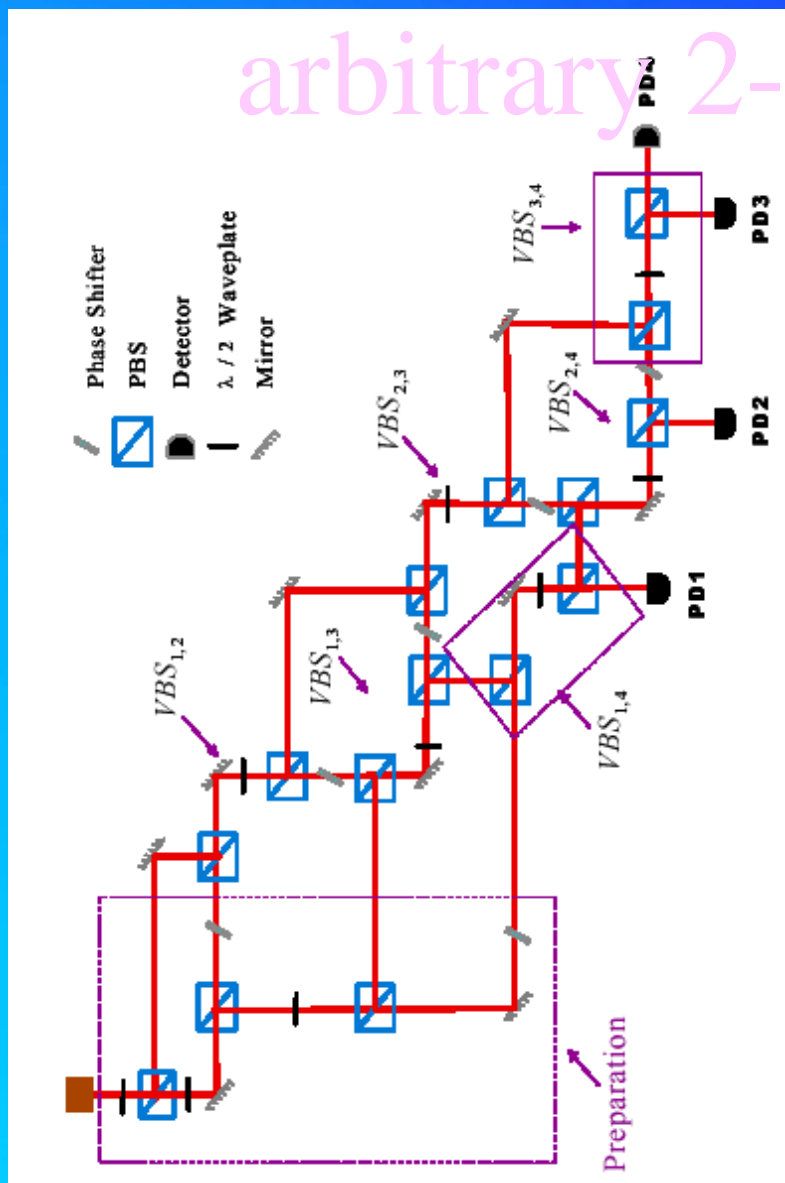

# Success!

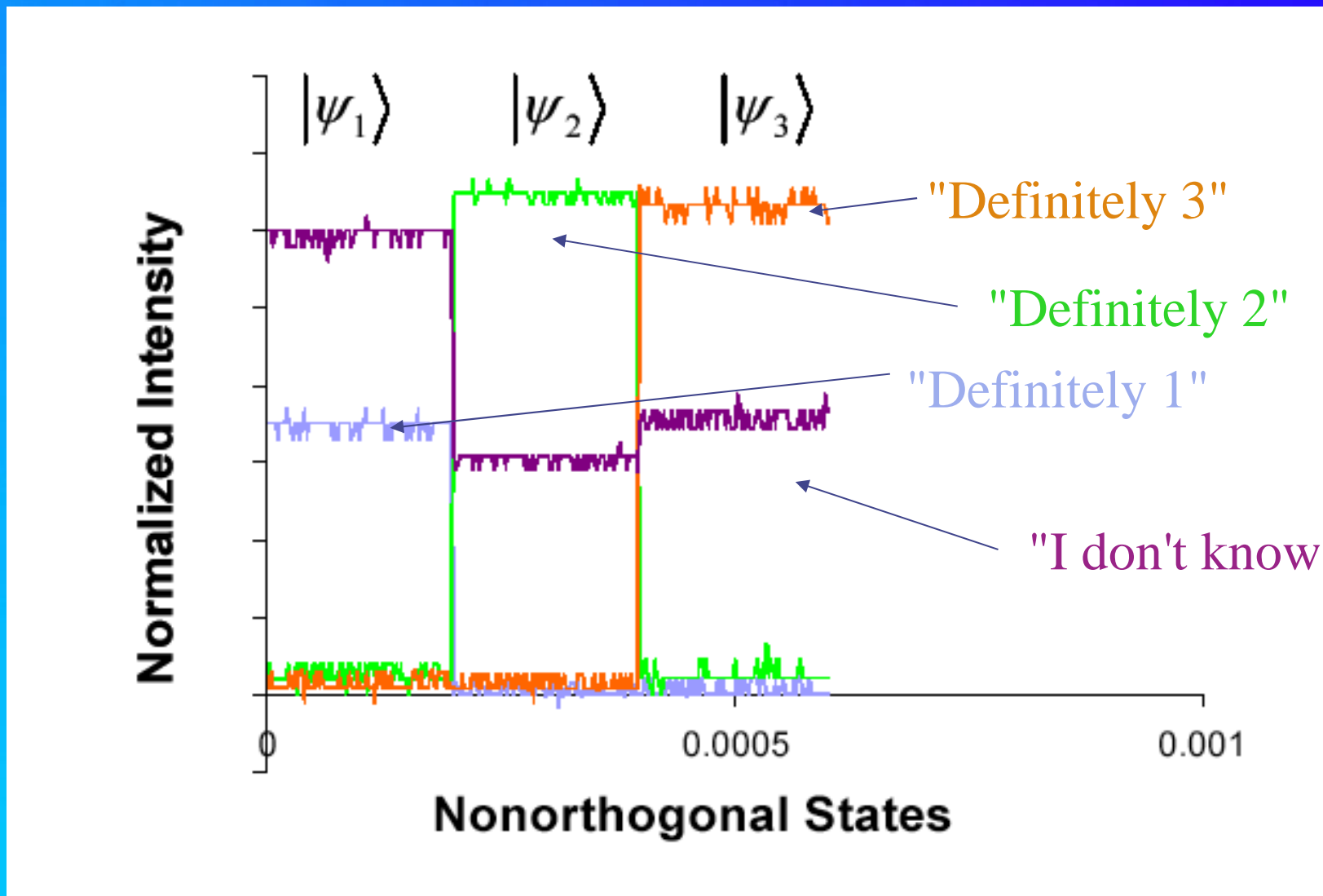

From  
Steinberg

The correct state was identified 55% of the time--  
Much better than the 33% maximum for standard measurements.

M. Mohseni, A.M. Steinberg, and J. Bergou, Phys. Rev. Lett. 93, 200403 (2004)

参考QCQI § 2.2, M.A. Nielsen and I.L. Chuang

M. Mohseni, A.M. Steinberg, and J. Bergou, Phys. Rev. Lett. 93, 200403 (2004)

谢谢